



aerospace
 climate control
 electromechanical
filtration
 fluid & gas handling
 hydraulics
 pneumatics
 process control
 sealing & shielding



BGT Series

Low Pressure Filters



ENGINEERING YOUR SUCCESS.

BGT Series

Applications

- Flows to 640 GPM
- 3 Micron Absolute to 120 Micron Absolute
- Disposable or Recleanable Elements
- Visual and Electrical Indicators
- Microglass elements
- Magnetic prefiltration
- Full flow bypass valve
- No internal leakage paths
- Inside-to-out flow thru element
- Complete contaminant removal during element service
- LEIF® element (600 and 1000 Series only)

BGT Tank Mounted Return Flow Filters

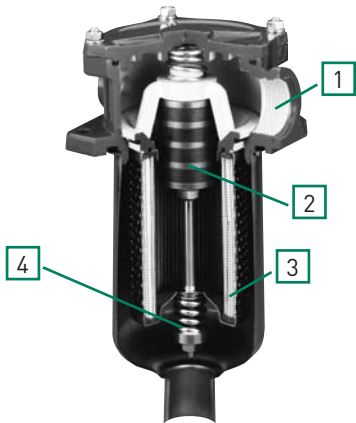

BGT Filters feature Parker's exclusive Magnetic Prefiltration core which collects ferromagnetic particles from fluid upstream of the filter element. This feature alone could save hundreds of dollars a year by protecting costly equipment from increased wear and malfunction by assuring that the fluid is as pure as possible when it leaves the filter. Even during bypass due to cold start up, ferris contaminant is collected by the magnetic core, a feature of importance on any fluid power system.

Take a close look and compare Parker features with any other filter.

1. Fluid flows through the inlet port into an enlarged area which reduces fluid velocity. Inlet flow does not impinge on the element.

2. Filtration begins with magnetic prefiltration of ferromagnetic particles in the full fluid flow upstream of the element, not downstream or in the reservoir. Built-in or system generated ferromagnetic wear debris (even particles smaller than the element rating) are collected by the high strength (3.0K Gauss) magnetic column. This results in extended element and oil life and reduced maintenance and downtime, which reduces overall operating cost.

3. Fluid passes through the element in an inside-to-outside direction, collecting particles inside the filter cartridge. This eliminates reinjection of contaminant during element change. Clean fluid then returns to the reservoir through the diffuser which prevents fluid aeration.

Normal return line filters, that flow outside-to-inside, allow contaminated fluid to drain back into the reservoir when the element is serviced.

4. Simplified bypass design and location prevents flushing previously collected contaminant back into the system. Since the element serves as the valve there is no troublesome separate valve to remove when changing elements. Magnetic filtration occurs even during bypass. All potential leakage paths are o-ring sealed to eliminate bypass leakage that occurs in loose fitting valve assemblies.

BGT Filters are available with disposable

Specifications

Housing Data:

Material:

Head – Aluminum Alloy
Diffusor – Steel
Internals – Carbon Steel and Aluminum
Seals – Nitrile (Standard), Fluorocarbon

Pressure Rating:

Static – 150 psi (10.3 bar)

Temperature Range:

Operating -40°F to +250°F
(-40°C to +120°C)

elements of several contamination class levels for use in all common fluids.

Optional accessories include visual and electric warning indicators that assure proper element service.

BGT Series

How To Size Tank Top Filters

Element Pressure Drop Factor:

Multiply the actual flow rate times the applicable ΔP factor to determine the pressure drop with a fluid viscosity of 140 SSU. Correct for other viscosities by applying the following formula: Flow rate (GPM) x filter factor x (new viscosity in SSU/140 SSU).

Flow/Pressure Drop Data

Fluid Conditions: Viscosity-140 SSU Sp. Gr. - 0.88

Media Code	600	Size Code 1000	2000
02Q (L)	.082	.0493	.0246
05Q (L)	.031	.0187	.0091
10Q (L)	.022	.0129	.0066
20Q (L)	.014	.0088	.0044

Example:

Element Size Code = 600
 Element Media Code = 10
 Filter Factor = .022 (From chart)
 Flow = 160 GPM
 Viscosity = 160 SSU

Formula:

$$160 \text{ GPM} \times .022 \times (160 \text{ SSU}/140 \text{ SSU}) = 4.0 \text{ PSID}$$

Element Data

Media Type	Absolute Rating	Multipass Test Results To ISO 4572 (Time Weighted Averages)						
		B ₃	B ₆	B ₁₀	B ₁₂	B ₂₀	B ₂₅	B ₃₆
Microglass III	3	≥100	800	2000	>5000	∞	∞	∞
Microglass III	6	8	≥100	1000	2000	>5000	∞	∞
Microglass III	10	6	22	≥100	≥200	>5000	∞	∞
Microglass III	20	-	2	8	20	≥100	≥200	>5000

Dimensions

BGT-13, BGT-15, BGT-17

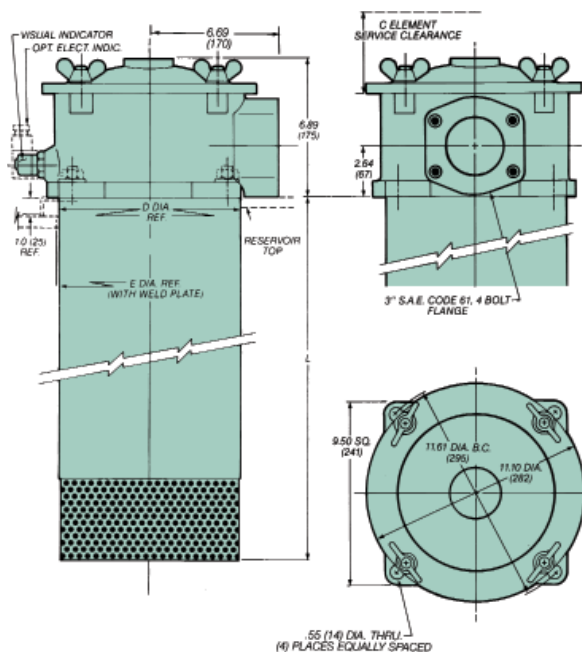

Drawings are for reference only.
 Contact factory for current version.

Return Line Filter - Series 4

Dimensions inches (mm)	BGT Filter Model		
	13	15	17
C	18.0 (457)	27.0 (686)	48.0 (1219)
L	16.75 (425)	25.20 (640)	47.25 (1200)
D	9.49/9.47 (241/240.5)		
E	10.25/9.70 (260/246)		

BGT Series

Parts List

Parts Breakdown BGT Series

Seals	
Part Number	Description
BGT 13, 15 or 17	
R-8875	Cover O-ring
SOR-90	Insert O-ring
SOR-85	Bypass Seals
R9875	Tank Gasket
SOR-115	Element O-Ring
Nitrile or Fluorocarbon	Material*

*Please specify seal material suffix when ordering
Fluorocarbon seals: "-V"

Bypass Assembly	
13, 15 or 17	Pressure
6903184	Blocked
4903020	4.5 PSID
4903004	12 PSID
4903008	22 PSID

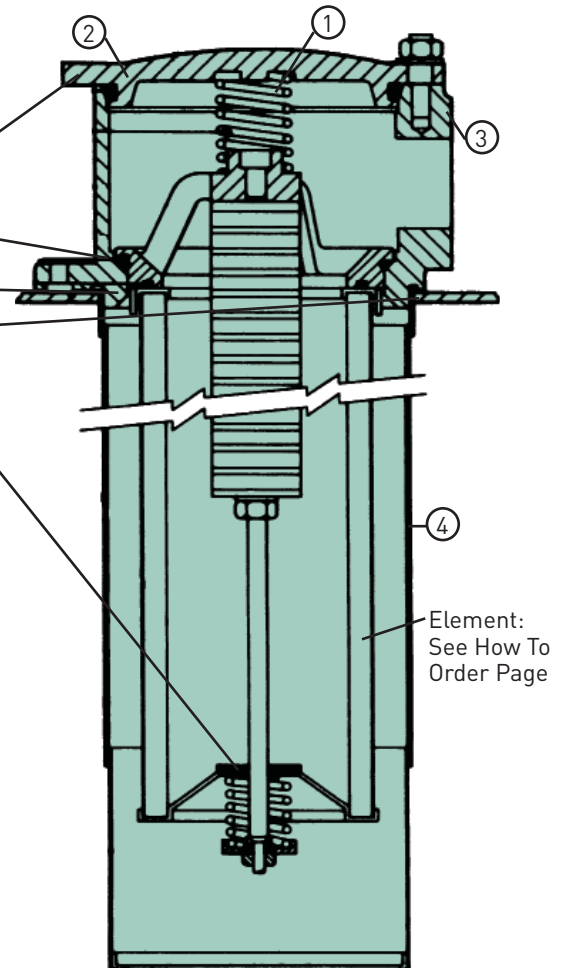

Item	Description	Material	Part Numbers		
			BGT-13	BGT-15	BGT-17
1	Top Spring	Steel	48371205		
2	Cover	Die Cast Aluminum	84.22.064.06 (5842206)		
3	Head	Die Cast Aluminum	5841032		
4	Diffusor	Steel	2110084	2110085	21100086

BGT Series

Operating And Maintenance Instructions Parker Model BGT Tank Top Filters

A. Mounting

1. Standard mounting.
 - a. Cut proper size hole in the top of the reservoir.
 - b. Drill holes for studs within the proper bolt circle.
 - c. Set the filter into the cutout hole and secure with proper size bolts, nuts and lock washers.
2. Utilize proper fittings.

B. Start-Up

1. Check for and eliminate leaks upon system start-up.
2. Check differential pressure indicator, if installed, to monitor element condition.

C. Service

1. An element must be serviced when the indicator indicates service is required.

NOTE: If the filter is not equipped with an indicator, the element should be serviced according to machine manufacturer's instructions.

D. Servicing Dirty Elements

1. Shut system down to assure that there is NO PRESSURE OR FLOW into the filter housing.
2. Remove the filter cover.
3. Remove the filter insert (bridge which holds the element in place).
4. Remove the bypass spring assembly or non-bypass plate from the stud.
5. Remove the contaminated cartridge with a twisting motion.
6.
 - a. Discard the disposable element cartridge.
 - b. Wash cleanable or mesh elements in a non-caustic solvent. Compressed air can be used to facilitate cleaning. Use care to prevent damage to the element during cleaning.

NOTE: Elements finer than 150 microns (100 mesh) may require special ultrasonic cleaning. Consult factory for recommendations.

E. Before Installing A New Element Cartridge

1. Clean the magnetic core with a lint-free cloth.
2. Check all seals and replace if necessary.

F. To Install A New Or Cleaned Element Cartridge

1. Lubricate all seals.
2. Mount new or cleaned Parker filter cartridge.

NOTE: For ease of mounting, hold the cartridge away from the magnetic core until the stud is through the hole in the bottom of the element. Then slide it up to securely seat it to the top of the bridge.

3. Install the bypass spring assembly or non-bypass plate, and tighten until snug.

NOTE: Older versions may have a cotter pin/castellated nut retained bypass spring. In these cases, the nut should be turned down the shaft until the cross drilled hole is visible in the base of a castellation and the cotter pin inserted and ends flared to lock the bypass assembly in place.

4. Re-install the insert into the filter housing, making sure that the top- spring is secure.
5. Re-install the cover. Torque the cover nuts to 22 ft./lbs.
Follow procedures B.1 and B.2.

BGT Series

How to Order

BOX 1	BOX 2	BOX 3	BOX 4	BOX 5	BOX 6	BOX 7	BOX 8
BGT	13	10QL	B	V	E	F48	1

BOX 1: Basic Assembly Symbol	Description
BGT	Return Filter

BOX 2: Housing Length Symbol	Description
11	3-390 L/min Return Filter (105 gpm)
12	3-500 L/min Return Filter (135 gpm)
13	4-600 L/min Return Filter (160 gpm)
15	4-1000 L/min Return Filter (265 gpm)
17	4-2000 L/min Return Filter (530 gpm)

BOX 3: Element Media Symbol	Description
02QL	<u>BGT11, 3-390 L/min</u> Leif® Microglass III Element
05QL	Leif® Microglass III Element
10QL	Leif® Microglass III Element
20QL	Leif® Microglass III Element
02QL	<u>BGT12, 3-500 L/min</u> Leif® Microglass III Element
05QL	Leif® Microglass III Element
10QL	Leif® Microglass III Element
20QL	Leif® Microglass III Element
02QL	<u>BGT13, 4-600 L/min</u> Leif® Microglass III Element
05QL	Leif® Microglass III Element
10QL	Leif® Microglass III Element
20QL	Leif® Microglass III Element
02QL	<u>BGT15, 4-1000 L/min</u> Leif® Microglass III Element
05QL	Leif® Microglass III Element
10QL	Leif® Microglass III Element
20QL	Leif® Microglass III Element
02Q	<u>BGT17, 4-2000 L/min</u> Microglass III Element
05Q	Microglass III Element
10Q	Microglass III Element
20Q	Microglass III Element

BOX 4: Seals Symbol	Description
B	Nitrile

BOX 5: Indicator Symbol	Description
P	Plugged Indicator Port
G	Pressure Gauge
S	Pressure Switch
V	Visual Differential Indicator
E	Electrical Differential Indicator

BOX 6: Bypass Symbol	Description
E	22 PSID Bypass (1,5 bar)

BOX 7: Ports Symbol	Description
F32	2" SAE Flange, Code 61
F48	3" SAE Flange, Code 61

BOX 8: Options Symbol	Description
1	No Options
TP	Weld Plate

Global products as identified are offered worldwide through all Parker locations and utilize a common ordering code.

